

Wooden Puzzle Vault

Clever design will keep them guessing

By Donald Horgan

While reading *The DaVinci Code* by Dan Brown, I was intrigued by the description of what he called a “cryptex,” or vault protected by a combination lock. After reading the passage describing the cryptex, I knew I had to design one in wood. The project is actually quite simple and can be put together in a weekend with tools most woodworkers have.

I was a police officer for many years and have used woodworking as the ultimate stress reliever. This project combines my love of reading, a life of law enforcement, and my passion for woodworking.

I worked my way through several prototypes and was excited to try out the finished product on my family and friends. The

reactions were priceless! With each new vault, my children bug me to give them “just the first letter.” My colleagues try to figure out a mechanical way around the lock. With a five-dial vault, using all 26 letters, there are 11,881,376 possible combinations! It is a great conversation piece and could be used to conceal a small gift for a special birthday or anniversary.

To start your vault, copy the patterns for the seven rings and attach them to the blank using spray adhesive. Cover the pattern with clear packaging tape. The side with the pattern attached will be called Side A. The opposite side will be called Side B.



Ben Fink (www.bensscrollsaw.com) and Lora Irish (www.carvingpatterns.com) worked together to craft this custom version for our publisher. For this project, we used 1/2"-thick stock for the end cap.

Vault: Preparing the Rings



1 Drill Side A of the rings. Drill a 1/16" (2mm)-diameter hole through the center of each ring so you can locate the center from either side. Be careful; the center is important to the smooth working of the vault. Using a 1 7/8" (48mm)-diameter Forstner bit, drill 1/4" (6mm) deep on six of the rings. The seventh, undrilled, ring will become the bottom ring. Drill a 1/16"-diameter by 1/16"-deep (2mm by 2mm) center pilot hole in the end cap.



2 Drill the holes in Side B. Turn the material over. Use the center holes as references to drill five 1 5/8"-diameter by 1/4"-deep (41mm by 6mm) holes. Do not drill the first ring—it will become the top ring—and do not drill the bottom ring. Then, drill 1 3/8" (35mm)-diameter holes through the centers of all seven rings. To reduce tearout, drill partway through from each side. Use the same bit to drill a 1/4" (6mm)-deep hole in the end cap.



3 Cut out each of the rings. Each of the five main rings will have a hollow core with a 1 7/8" (48mm)-diameter opening on Side A, a 1 5/8" (41mm)-diameter opening on Side B, and a 1 3/8" (35mm)-diameter lip in the center. I use a #7 blade to cut the perimeters of the rings and the end cap. Cut 1/16" (2mm) outside the lines and sand to the lines with a belt or disk sander.



4 Add a rabbet around each ring. With Side A facing up on a router table, use a 1/4" (6mm)-radius rabbeting bit to cut a 1/4" by 1/4" (6mm by 6mm) rabbet around each ring. Use a push block to hold the ring. Your fingers will be close to the bit. This rabbet allows the rings to nest inside of each other.



5 Cut out and attach the letter dial marking templates to the five interior rings. If you cut precise rings, the templates will wrap around the rings, line up end to end, and divide the rings into 26 equal sections. If the rings are not the correct circumference, cut a little away from the lines on each space in the next step to spread the difference over several spaces.



6 Define the letter spaces and cut the keyway. Use a #7 or finer blade to score the spaces for the letters on the outsides of the rings. Cut one notch on the interior of each ring corresponding to a letter space on the outer perimeter. These notches become the keyway, allowing you to remove the vault. Randomize the notch locations with respect to the grain so the grain pattern can't be used to solve the code.

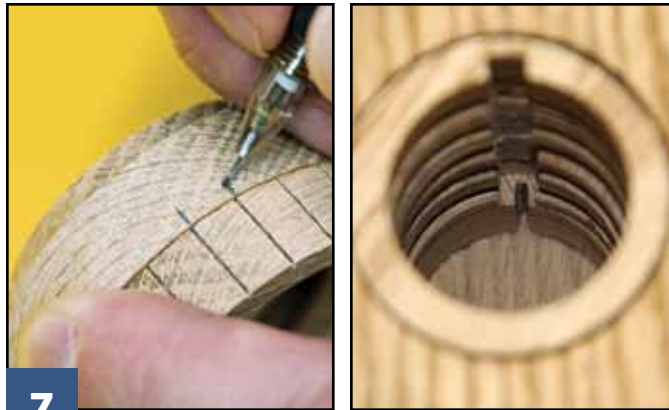

7 Mark the end rings. Stack a letter ring next to each end ring. Transfer lines for one letter space and score the lines using the saw. Cut the interior notch on the top ring, matching the scored lines. On the bottom ring, center a notch between the scored lines, just wide enough for a nail, to prevent wiggling of the vault.



9 Mark the location of the locking pins. Mark a line the length of the dowel. Place the dowel (with the opening on top) in the bottom ring. Mark the top of the ring on the line. Add the first ring and mark the top on the dowel line. Use the same method to mark the location of the next three rings. This removes any discrepancies that may prevent the rings from turning.



11 Cut the access door. Put the dowel inside the rings and mark the location of the top of the seventh ring. Cut the door just below the mark, on the side opposite the pins. An angled cut on the ends will help keep the door closed.

VAULT: MAKING THE COMPARTMENT



8 Drill the hole in the center compartment. The interior compartment is made from a 1 3/8" (35mm)-diameter dowel. Cut the dowel to a length of 4 3/8" (111mm). Mark the center on one end. Drill a 7/8"-diameter by 3 3/8"-deep (22mm by 86mm) hole. Be sure to keep the hole square to the dowel. Clamp the dowel and use a drill press.

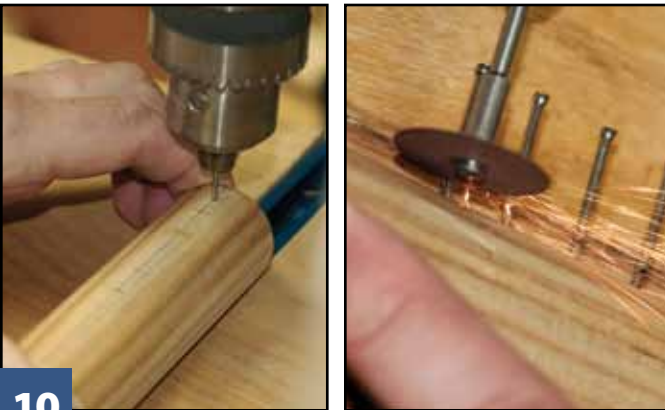

10 Insert the pins. Mark 3/8" (10mm) below the first mark on the dowel. This will house the pin that fits into the slot on the bottom ring. Clip both ends off of a 3d finish nail and use it to drill a hole at the mark you just made and at each of the four marks for the letter dials. Clip the points off of five more nails and glue them in place with cyanoacrylate (CA) glue. Cut the nails to 1/8" (3mm) tall.

VAULT: MAKING THE HOUSING



12 Cut the end pieces. Drill a 5/16"-diameter by 1/8"-deep (8mm by 3mm) hole in the corners of both framework ends as shown on the pattern. Cut the rounded corners and drill a 1 7/8" (48mm) hole through the center of one piece. Sand the edges or round them on the router table. Round the edges of the end cap with a 1/8" (3mm)-radius round-over bit.



13 Cut the dowel supports. Measure the total height of the seven rings stacked one on top of another. It should be close to 3 1/2" (89mm). Add twice the actual depth of the 5/16" (8mm)-diameter holes in the end caps and an additional 1/16" (2mm). This gives enough room for the rings to turn easily. Cut four 5/16" (8mm)-diameter dowels to this length. Dry-fit all the pieces together, including the end cap and dowel.



14 Trim the dowel and determine your code. Measure the space between the frame and the end cap. Trim that much minus 1/32" (1mm) from the open end of the dowel so the end cap clears the frame. Write the code letters in the spaces over each notch on the letter dials and continue the alphabet from those letters (see sidebar on page **). Darken the single spaces on the two end rings.

VAULT: FINISHING THE PROJECT



15 Assemble the cryptex. Glue the bottom ring in the middle of the solid framework end, with the notch pointing to the center of one side. Glue the top ring into the hollow framework end, aligning the notch in the center to match the bottom. Keep the grain running the same direction on the ends and the end cap.



16 Glue the final pieces in place. Glue the support dowels to the bottom, stack the rings in the proper order, and glue the top framework in place. Align the pointer on the end cap with the pins on the dowel, and glue it onto the open end of the dowel. Clamp both assemblies and allow to dry. Apply a clear spray finish.

Materials:

- Red oak, 3/4" (19mm)-thick: rings and end cap, 5 1/2" x 11" (140mm x 279mm)
- Red oak, 1/4" (6mm)-thick: framework ends, 3 1/2" x 7" (89mm x 178mm)
- Dowel, 5/16" (8mm)-diameter: 18" (457mm) long
- Dowel, 1 3/8" (35mm)-diameter: 5" (127mm) long
- 3d finishing nails: 6 each
- Spray adhesive
- Spray finish: clear
- Wood glue
- Packaging tape: clear

Tools:

- Blades: #7
- Drill press
- Twist bit: 1/16" (2mm diameter)
- Forstner bits: 1 7/8" (48mm), 1 5/8" (41mm), and 1 3/8" (35mm) diameters
- Brad point or Forstner bit: 5/16" (8mm)-diameter
- Spade or Forstner bit: 7/8" (22mm)-diameter

The author used these products for the project. Substitute your choice of brands, tools, and materials as desired.

SPECIAL SOURCES:

1 3/8" (35mm)-diameter dowels are available from Woodcrafter.com at 800-704-3772 or www.woodcrafter.com.

Materials & Tools

- Router and bits: 1/8" (3mm) and 1/4" (6mm)-radius round-over; 1/4" (6mm) rabbeting
- Belt or disk sander
- Rotary-power tool with cut-off wheel or diagonal cutters
- Ultra-fine permanent marker
- Table saw (optional)
- Miter saw (optional)

Making It Difficult

The more equidistant the pins are from the bottoms of the rings, the harder it will be to exploit the mechanical weaknesses to solve the code. You can create false mechanical "hints" by creating divots in the bottom side of the inner rings to give the illusion of a pin sliding up into a notch. This is especially effective when placing the divots on vowels, and the letters R, S, T, and L.

Provide a hint that will not give away the answer too quickly. Cryptic rhymes or questions work well.



Don's original cryptex was unlocked with the code word ENJOY.

Neater Letters

Printing neat letters on the round dials can be somewhat of a challenge. With some practice and a steady hand, you can get good results with a fine-tip marker or a woodburner.

An alternate method is to add the alphabet with rub-on letters used for scrapbooks. They are available at many craft stores in a variety of fonts and once sealed, the letters are very durable. One source is Making Memories, www.makingmemories.com.



Donald Horgan lives in Antioch, Calif. A self-taught woodworker, Don has been scolling for 17 years.

Assembly drawing

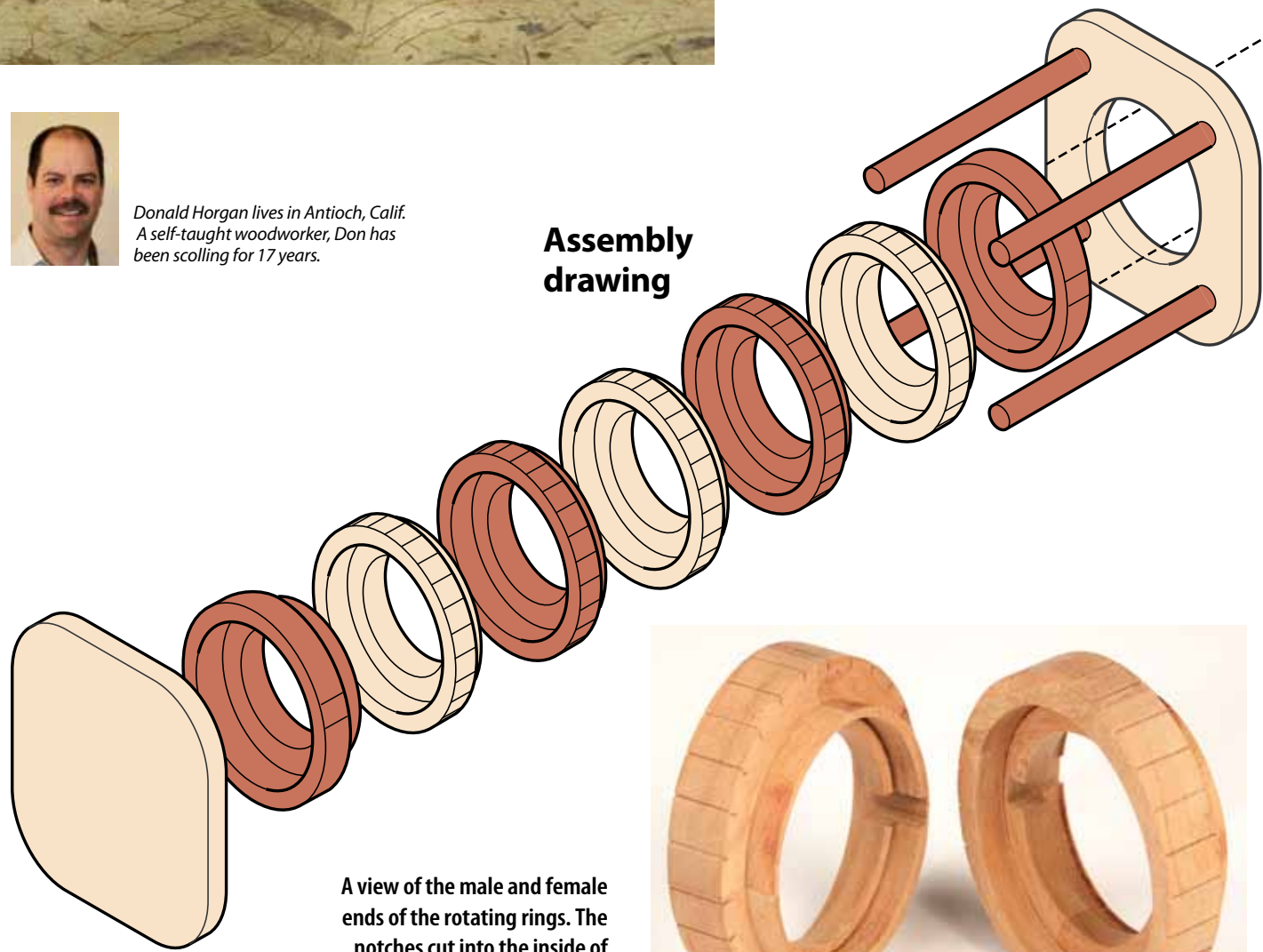

A view of the male and female ends of the rotating rings. The notches cut into the inside of the rings make a keyway for the pins to follow.

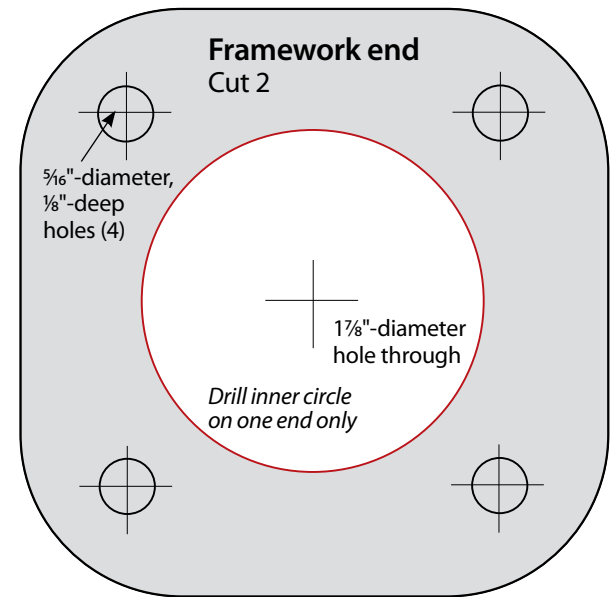
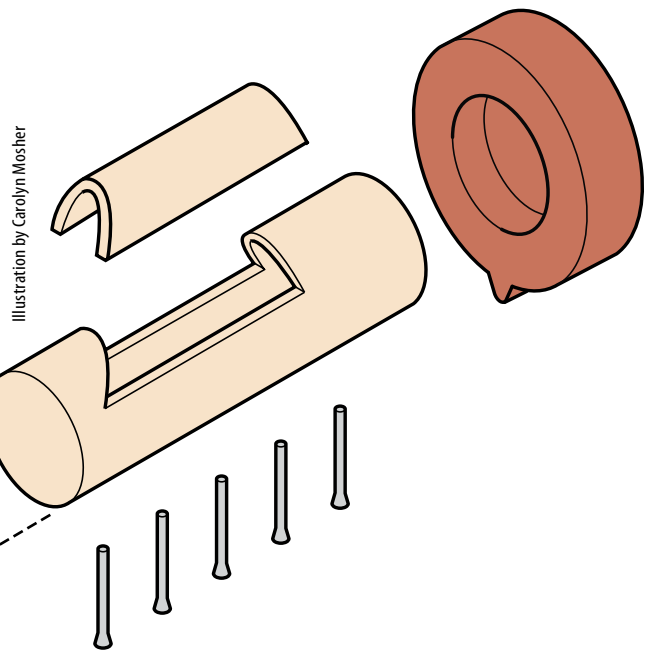

Cryptex patterns

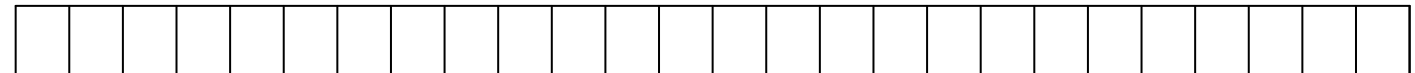
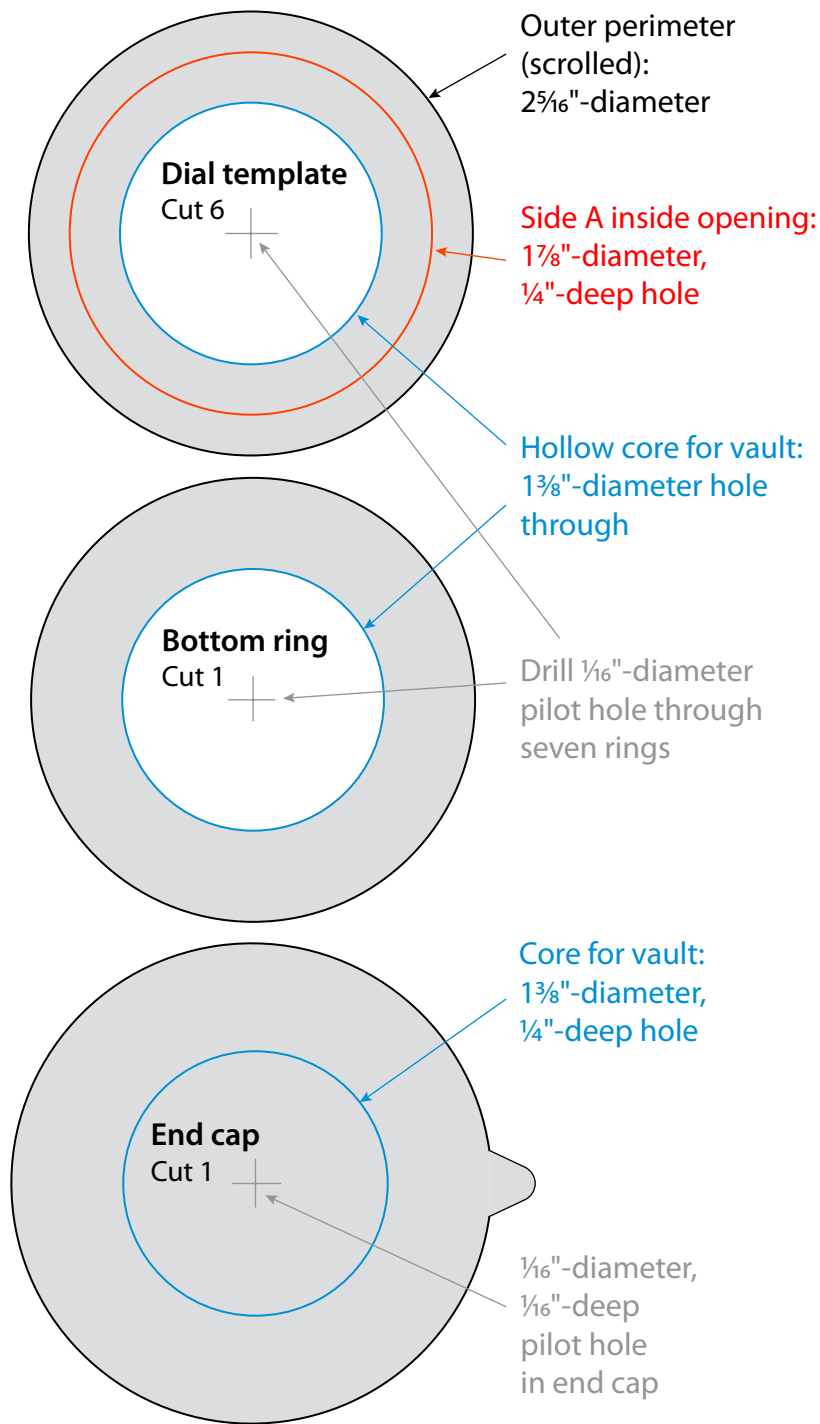

Letter dial marking template - Make 5 copies